

BACK VIEW OF FUSE BOX AND BULK HEAD CONNECTOR ARE SHOWN.

INSTALLING THE FUSE BOX
FIGURE "A"

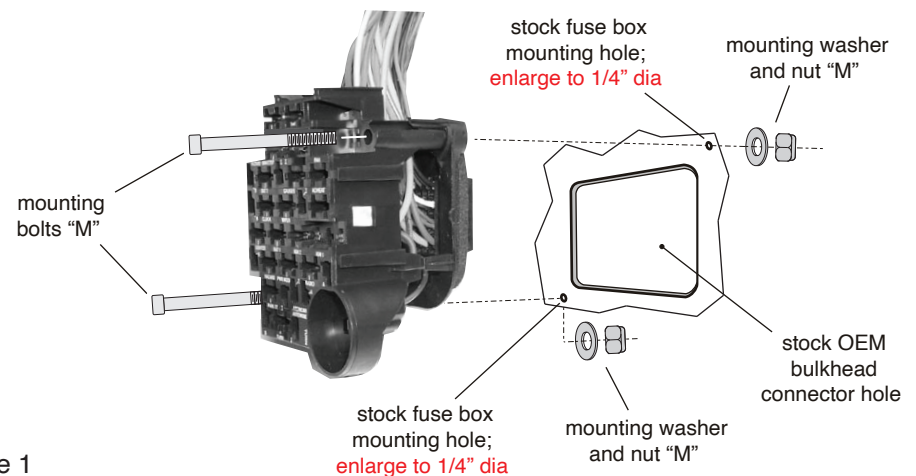

1. Locate the stock OEM bulkhead connector hole, in the driver side of the firewall.
2. Enlarge the (2) mounting holes, to 1/4" (.25").
3. Mount the fuse box, with the flasher can in the bottom right corner, as shown in **Figure A**.
4. Use the (2) bolts, nuts and washers "M", to attach the fuse box to the firewall.



www.americanautowire.com 856-933-0801

PART #	510574
DESCRIPTION:	1976-86 Jeep CJ Classic Update Series Kit
92970861	Rev 2.0 06/01/2023

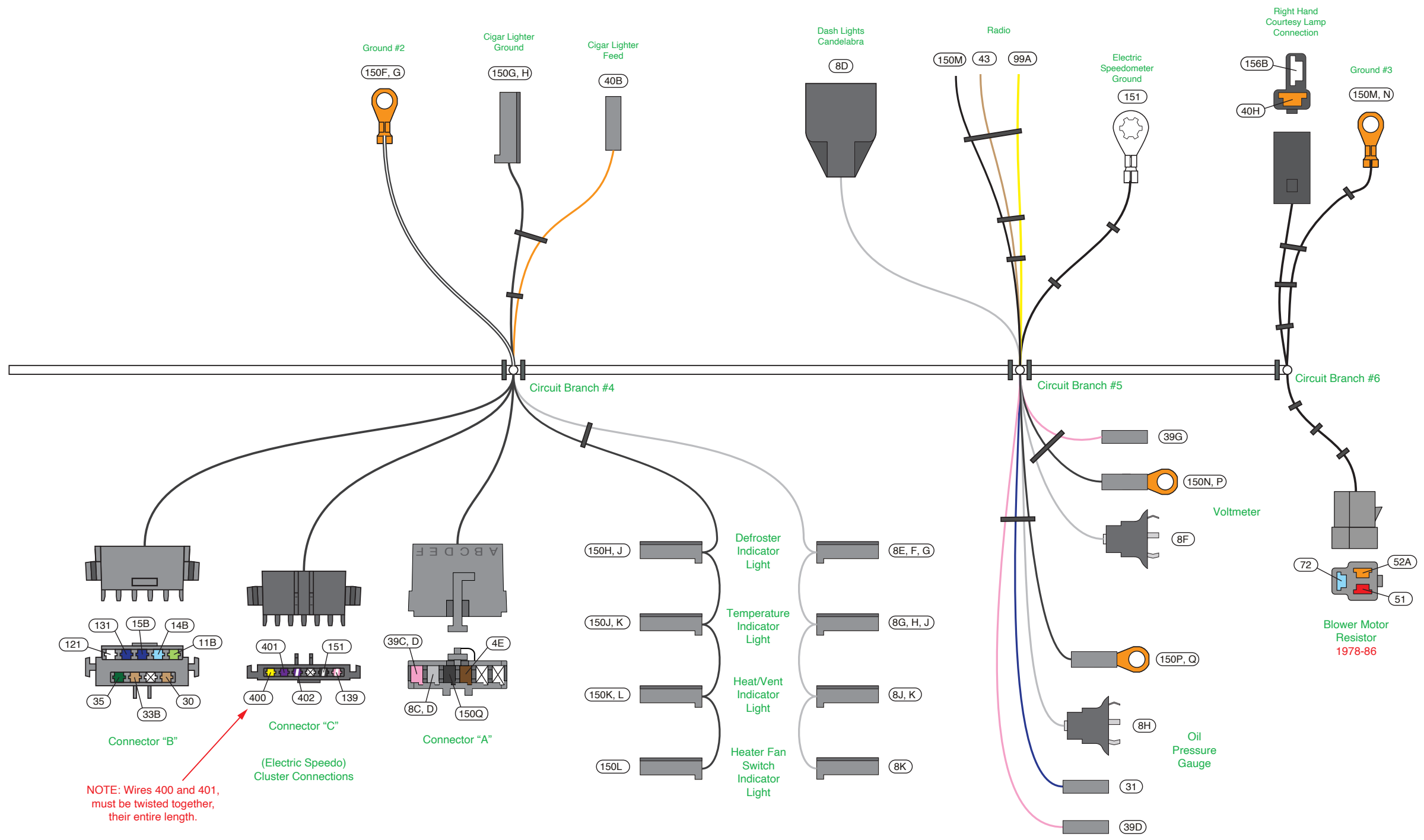

NOTE: Wires 400 and 401, must be twisted together, their entire length.



PART # **510574**
 DESCRIPTION:
 1976-86 Jeep CJ
 Classic Update Series Kit

92970861 Rev 2.0 06/01/2023

Legend:

A  (Clock Light Jumper Harness - Reference, 1 pc.)

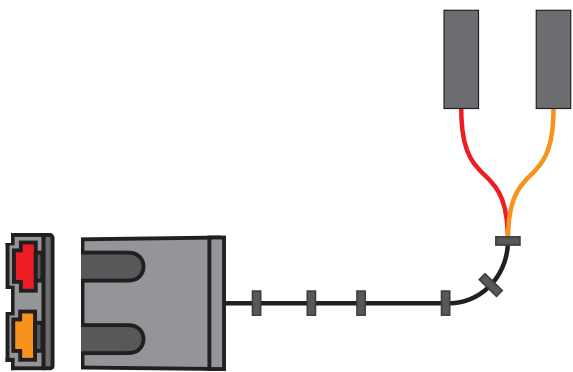
B  (1976-77 Heater System Jumper Harness - Reference, 1 pc.)

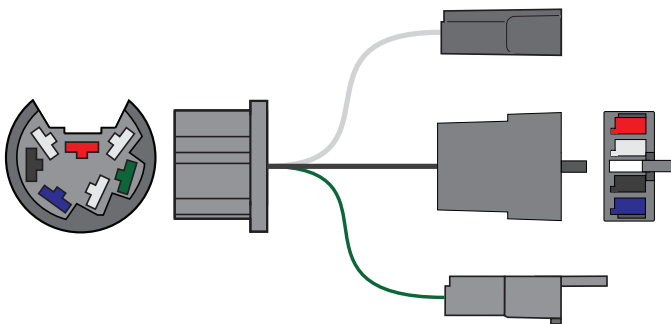
C  (1983-86 Wiper System Jumper Harness - Reference, 1 pc.)

D  (Neutral Safety Switch Jumper Harness - Reference, 1pc.)

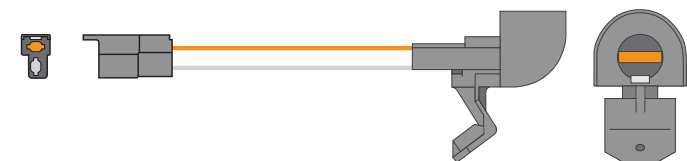
E  (Courtesy Light Jumper Harness - Reference, 2 pcs.)

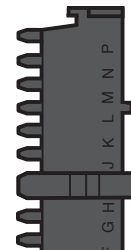
F  (Pack-Con 14-way male connector, 1 pc.)

G  (Pack-Con male terminal, 12 pcs.)

H  (56 series double female terminal, 7 pcs.)

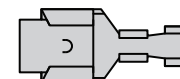
J  (56 series single female terminal, 7 pcs.)

K  (small male bullet terminal, 4 pcs.)

L  (small rubber sleeve, 4 pcs.)

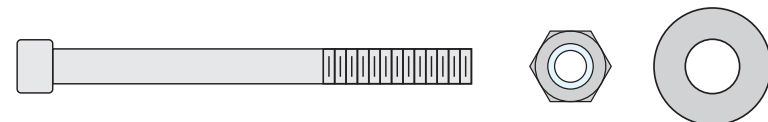
M  (1/4" bolt, nut and washer; 2 of each)

N  (large male bullet terminal, 4 pcs.)

P  (large rubber sleeve, 4 pcs.)

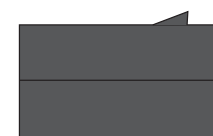
Q  (56 series 2-way female connector, w/lock wedge, 1 pc.)

R  (10-32 nut, 4 pcs.)



www.americanautowire.com 856-933-0801

PART # **510574**

DESCRIPTION:

1976-86 Jeep CJ

Classic Update Series Kit

92970861 Rev 2.0 06/01/2023

Note: Prior to installing the Dash Harness, obtain the Fuse, Flasher and Relay Kit #510580 and plug all of the Fuses and Flashers in the Fuse Box (See Figure #1, on this page, for location of fuses and flashers). Install the Horn Relay and the Headlamp Relays to the Dash Harness (see circuit branch #1). If you have the factory Fog Light System, plug the Fog Light Relay into the Fog Light Relay connector (see Circuit Branch #2). The Horn Relay has three male blades, and the other three relays are the same and have five blades each.

Fuse Box Attachment

Locate the original factory Fuse Box Bulkhead hole in the upper left corner of the Dash Panel. You will have to open up the two Fuse Box mounting screw holes to allow clearance for the 1/4" x 20 x 3" bolts "M" (see Page 3 – the Legend). Drill out the two holes using a 1/4" drill (see figure "A", Page 3). Now attach the Fuse Box/Bulkhead Assembly to the Firewall using the Bolt, Nut and Washer "M".

Dash Harness Installation Instructions

The Dash Harness routing will be the same as the original factory Instrument Panel Wiring Harness routing. Be sure to duplicate this routing. Now proceed to the individual Circuit Branch Instructions below.

Circuit Branch #1

Power Accessory Connector Use the provided 6-way empty connector, which is attached to the 6-way **Power Accessory** connector on the Dash Harness, and terminals "H" and "J" (see Page 3 – The Legend) to add power wires (not provided) for the following systems:

Wire #	Wire Color	Printing	Fuse Block	Fuse Rating	Description
103	Tan	Fuel Pump	FUEL	20A	Ignition feed for Electric Fuel Pump.
105	Red	no printing	BAT 1	20A	Battery feed for Power Locks or any option that requires B+.
106	Pink	POWER WINDOWS	PWR WDO	30A	Ignition feed for Power Windows or any option that requires an Ignition feed.
107	Brown	Ignition SW ACCY	ACCY 1	30A	Accessory feed for Cruise Control or any option that requires an Ignition Accessory feed.

Dimmer Switch Connector Route this wiring branch to the **Dimmer Switch (500042)**, which is included in this Dash Kit, and connect. Now attach the Dimmer Switch to the floor pan (bolts not included).

Wire #	Wire Color	Printing	Description
10	Yellow	DIMMER SW FEED	Feed from the Headlight Switch.
11A	Light Green	HEADLIGHT-HI BEAM	Trigger feed to the High Beam Relay.
12A	Tan	HEADLIGHT-LOW BEAM	Trigger feed to the Low Beam Relay.

Horn Relay Connector If you haven't already; now plug the Horn Relay (included in kit #510580) into this connector.

Wire #	Wire Color	Printing	Description
2D	Red	12V BATTERY	12v Battery feed to the Horn Relay.
28	Black	HORN RELAY GROUND	Relay ground circuit to the Steering Column.
29	Dark Green	HORN	Feed to the Horn.

Rear Body #1 Connector This 6-way connector will plug into the 6-way connector of the Rear Body Harness (see the Rear body Harness Kit 510577).

Wire #	Wire Color	Printing	Description
17A	Light Blue	THIRD BRAKE LIGHT	Feed for an aftermarket Third Brake Light.
30	Tan	GAS GAUGE	Fuel Tank Sender.
40F, G	Orange	12V BATTERY-FUSED	Feed to the Dome Light.
156A	White	CTSY GROUND	Dome Light ground to the Courtesy Switches.

Rear Body #2 Connector This 4-way connector will plug into the 4-way connector of the Rear Body Harness (see the Rear body Harness Kit 510577).

Wire #	Wire Color	Printing	Description
9A	Brown	REAR RUNNING LIGHTS	Feed for the Tail Lights, License Light, and the Rear Side Marker Lights.
18	Yellow	LEFT REAR TURN	Feed to the Left Rear Stop and Turn Light.
19	Dark Green	RIGHT REAR TURN	Feed to the Right Rear Stop and Turn Light.
24	Light Green	BACK UP LT SW	Feed from the Back-up Light Switch to the Back-up Lights.

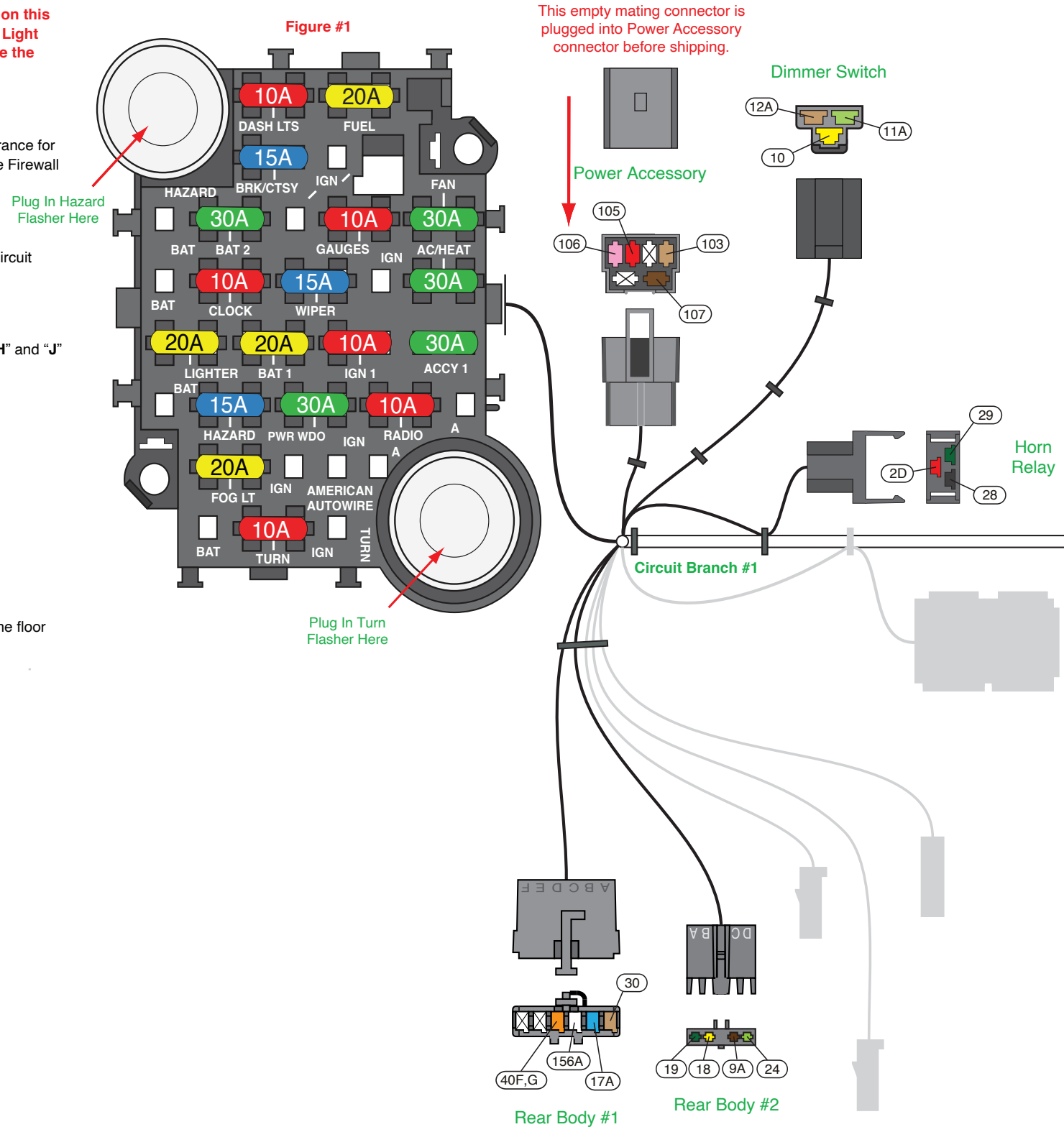

This empty mating connector is plugged into Power Accessory connector before shipping.



American Autowire

www.americanautowire.com 856-933-0801

PART # **510574**

DESCRIPTION:

1976-86 Jeep CJ Classic Update Series Kit

92970861 Rev 2.0 06/01/2023

Rear Body #3 Connector This 1-way black connector will plug into the 1-way black connector of the Rear Body Harness (see the **Rear Body Harness Kit 510577**).

Note: Wire 140 is included in the Front Light, the Dash, and the Rear Body Harnesses. This wire does not go through the Fuse Block but is expected to be connected to a Relay Kit in the Engine Compartment, with inline circuit protection (see optional American Autowire (AAW) Universal Relay Kit 500479, or Universal Waterproof Relay Kit 500093). This wire can be used as a feed for Driving Lights or for another Aftermarket option.

Wire #	Wire Color	Printing	Description
140	Orange	no printing	Feed for aftermarket Driving Lights (optional Relay Kit required).

Rear Body #4 Connector This 1-way white connector will plug into the 1-way white connector of the Rear Body Harness (see the **Rear Body Harness Kit 510577**).

Note: Wire 105A is included in the Dash Harness and the Rear Body Harness, and is a B+ circuit protected by a 20 amp fuse (BAT 1 in the Fuse Block). The wire can be used to feed a Rear Power Outlet or any other option that requires B+ and be protected by a 20A fuse.

Wire #	Wire Color	Printing	Description
105A	Red	no printing	Feed for an aftermarket Rear Power Outlet or an option that requires a B+ feed.

Park Brake Switch Connector Plug this connector onto your **Park Brake Switch**.

Wire #	Wire Color	Printing	Description
33	Tan	BRAKE LIGHT/SWITCH	Wire from the Brake Warning Light to the Park Brake Switch.

Headlight Relays These relays (included in kit #510580) are provided to allow for the use of higher current Head Lights and will reduce the load on the Head Light Switch. Each relay is rated at 30A. If you haven't plugged in the relays, do so now. **Note: Your headlights will not operate without these relays plugged in.**

Wire #	Wire Color	Printing	Description
11A	Light Green	HEADLIGHT-HI BEAM	High Beam Relay trigger feed from the Dimmer Switch.
11B	Light Green	HI BEAM INDICATOR LIGHT	Feed to the High Beam Indicator Light in the Cluster.
11C	Light Green	HEADLIGHT-HI BEAM	Feed to the High Beam Headlights.
12A	Tan	HEADLIGHT-LOW BEAM	Low Beam Relay trigger feed from the Dimmer Switch.
12B	Tan	HEADLIGHT-LOW BEAM	Feed to the Fog Light Switch so that the Fog Lights only operate with the Low Beam Headlights.
12C	Tan	HEADLIGHT-LOW BEAM	Feed to the Low Beam Headlights.
104,104A	Orange	12V BATTERY FUSED	Fused Battery Feed for the Headlight Relays.
150,150A	Black	GROUND	Ground for the Headlight Relays.

Circuit Branch #2

Ground #1 **Note:** Be sure to attach this ground ring terminal to a good vehicle ground. If not attached correctly, your Headlights, Fog Lights and Clock will not be functional.

Wire #	Wire Color	Printing	Description
150,150B	Black	GROUND	Ground for the Headlight Relays, the factory Fog Light System, and the factory Clock.

Left Hand Courtesy Light Connector Plug into one of the **Courtesy Light Jumper Harnesses "E"**.

(See Page 3 – the Legend) and attach to the Lower Instrument Panel. Note: Install a #631 light bulb (not included with this kit) into the socket of the Courtesy Light Jumper.

Wire #	Wire Color	Printing	Description
40G, H	Orange	12V BATTERY-FUSED	Fused Battery feed for the Courtesy Lights.
156, 156A	White	CTSY GROUND	Courtesy Light ground through the Headlight Switch.

Fog Light Switch Connector This connector will mate to your original factory **Fog Light Switch**.

Wire #	Wire Color	Printing	Description
12B	Tan	HEADLIGHT-LOW BEAM	Feed to the Fog Light Switch.
34	Purple	no printing	Trigger feed for the Fog Light Relay.
150B, C	Black	GROUND	Ground for the Fog Light Switch "On" light.

NOTE: The Courtesy Light Jumper Harness, from Page 3, that plugs into the connector at branch 2 on this page, uses a # 631 bulb (not included with this kit). They may be purchased at any auto parts store.

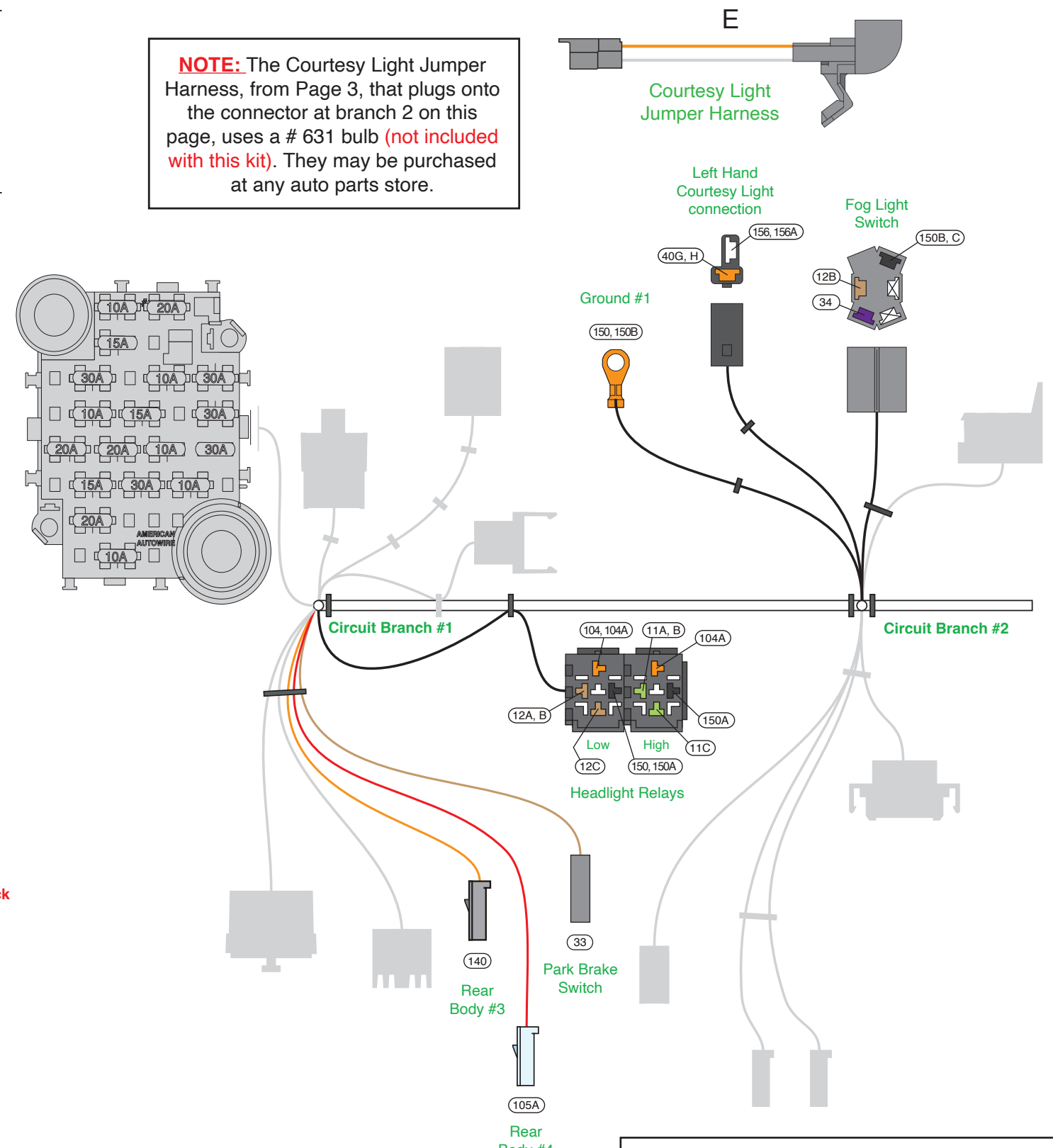

**American
Autowire**

www.americanautowire.com 856-933-0801

PART # **510574**
DESCRIPTION:
**1976-86 Jeep CJ
Classic Update Series Kit**

92970861 Rev 2.0 06/01/2023

Fog Light Relay Plug the **Fog Light Relay** (included in kit #510580) in, if you have the optional factory Fog Light System, and haven't done this already.

Note: The Fog Lights will only operate when the Low Beam Headlights are on.

Wire #	Wire Color	Printing	Description
34	Purple	no printing	Trigger wire for the Fog Light Relay.
40A	Orange	12V BATTERY-FUSED	Fused Battery feed for the Fog Lights.
150C, D	Black	GROUND	Ground for the Fog Light Relay.
500	Black	FOG LAMPS	Feed to the Fog Lights.

Clock Connector Plug this connector into the optional factory **Clock**.

Wire #	Wire Color	Printing	Description
99B	Yellow	CLOCK BAT	Battery feed for the Clock.
150D	Black	GROUND	Ground for the Clock.

Clock Light Jumper Harness If you have a factory Clock, this loose piece **Clock Light Jumper Harness "A"** (see **Page 3 – the Legend**), will provide a wire and light socket for the illumination of the Clock when the Dash Lights are on. Obtain the **Clock Light Jumper Harness "A"** and route the socket end to the Clock. Install a light bulb #1895 or equivalent (not included in this kit), into the socket and plug into the Clock. Route the other end of the Jumper Harness to the Dash Lights Candelabra, found in **Circuit Branch #5**, and plug into the **Candelabra**.

Wire #	Wire Color	Printing	Description
8X	Gray	DASH LIGHTS	Feed to Clock Light.

Headlight Switch Indicator Light Connectors Plug these two connectors onto your **Headlight Switch Indicator Light**. For all of the Indicator Lights, either connector can plug onto either terminal of the light as long as you have one feed and one ground for each Indicator Light. This light will illuminate when the Dash Lights are on.

Wire #	Wire Color	Printing	Description
8, 8A	Gray	DASH LIGHTS	Feed to the Headlight Switch Indicator Light.
150E	Black	GROUND	Ground for the Headlight Switch Indicator Light.

Headlight Switch Connector Plug this connector onto the **Headlight Switch (510583)**, which is included in this kit, and connect. Now attach the Headlight Switch to the dash.

Wire #	Wire Color	Printing	Description
2F	Red	12V BATTERY	Battery feed to Headlight Switch for Headlights.
9	Brown	PARK LIGHTS	Feed out to Front Park Lights
10	Yellow	DIMMER SW FEED	Feed out to Dimmer Switch for Headlights.
40C	Orange	12V BATTERY-FUSED	Fused Battery feed to Headlight Switch for Park Lights and Courtesy Lights.
40D	Orange	BRAKE SW	Fused Battery feed from the Headlight Switch to the Brake Light Switch.
44	Dark Green	no printing	Headlight Switch feed to Fuse Block for Dash Lights.
156, 156B	White	CTSY GROUND	Courtesy Light/Dome Light ground through Headlight Switch.

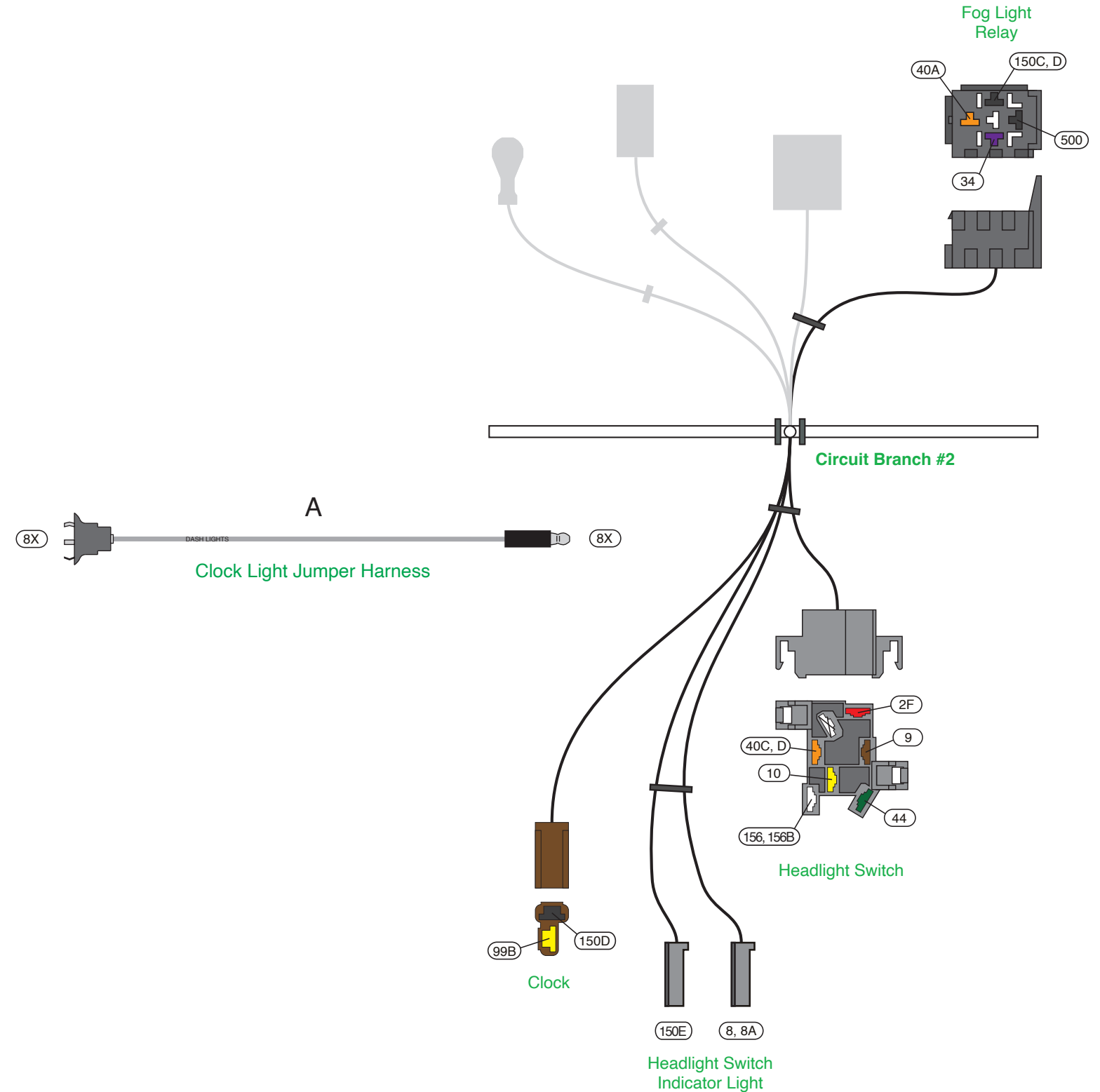

www.americanautowire.com 856-933-0801

PART # **510574**
 DESCRIPTION:
 1976-86 Jeep CJ
 Classic Update Series Kit

92970861 Rev 2.0 06/01/2023

Circuit Branch #3

Heater System **Note: There are two different Heater Systems available. For the 1976-77 vehicles, there is a 2-speed system and for the 1978-86 vehicles, it is a 3-speed system.**

For the **1976-77 vehicles**, there is a **2-speed Heater System** which consists of a three position Heater Switch (Off, Low, and High) and a 2-Speed Blower Motor, which is located in the interior of the vehicle. For this system you will need to use the **1976-77 Heater System Jumper Harness "B"** (See Page 3 – the Legend) and the **Heater Switch #2 Connector**, which is part of the Dash Harness Circuit Branch #3. The 3-way **Heater Switch #1 Connector** in the Dash Harness will **not** be used and can be taped back to the main trunk of the Dash Harness.

Obtain the **1976-77 Heater System Jumper Harness** and plug the 2-way connector to the **Heater Switch** (See **photo #2**). Note that there are raised nibs on the Heater Switch terminal blades and the 2-way connector can only go on one way. Obtain the **Heater Switch #2 Connector** from the Dash Harness and plug it onto the **Heater Switch**. There is also a raised nib for this 1-way connector and it can only go on one way. Now route the orange wire (circuit 52H) and the red wire (circuit 51H), from the **1976-77 Heater System Jumper Harness**, to the Blower Motor. Cut the factory connectors from the original factory Blower Motor pigtail, and slide on the small sleeve "L" to each wire, crimp on the small bullet terminal "K" to each wire of the Blower Motor (See Page 3 – the Legend) for the parts, and slide the sleeve "L" over the crimped portion of terminal "K". Now connect the red wire (low speed) and the orange wire (high speed) to the **Blower Motor Pigtail Wires**.

For the **1978-86 vehicles**, there is a **3-speed Heater System** which consists of a four position Heater Switch (Off, Low, Medium, and High), a Blower Motor Resistor, and a Blower Motor. The switch and the resistor are located inside the vehicle and the connection to the Blower Motor is in the Engine Compartment. You will **not** use the **1976-77 Heater System Jumper Harness "B"** but you will use both of the **Heater Switch Connectors (#1 and #2)** which are part of the Dash Harness.

Obtain the **Heater Switch #1 and #2 connectors**, which are in **Circuit Branch #3**, and plug them onto the **Heater Switch** (See **photo #3**).

1976-77 Heater System Jumper Harness

Wire #	Wire Color	Printing	Description
51H	Red	no printing	Blower Motor Low Speed.
52H	Orange	no printing	Blower Motor High Speed.

Heater Switch Connector #1

Wire #	Wire Color	Printing	Description
51	Red	no printing	Blower Motor Low Speed.
52, 52A	Orange	HEAT/AIR	Blower Motor High Speed.
72	Light Blue	no printing	Blower Motor Medium Speed.

Heater Switch Connector #2 **Note: In addition to supplying a 12V feed for the original factory Heater System, this connector can also be used as the Heater/AC Feed for an Aftermarket Heater/AC System.**

Wire #	Wire Color	Printing	Description
50	Brown	HEATER/AC FEED	Fused feed for the Heater System.

Wiper Switch Indicator Light Connectors Plug these two connectors onto your **Wiper Switch Indicator Light**. This light will illuminate when the Dash Lights are on.

Wire #	Wire Color	Printing	Description
8A, B	Gray	DASH LIGHTS	Feed to the Wiper Switch Indicator Light.
150E, F	Black	GROUND	Ground for the Wiper Switch Indicator Light.

PHOTO #2

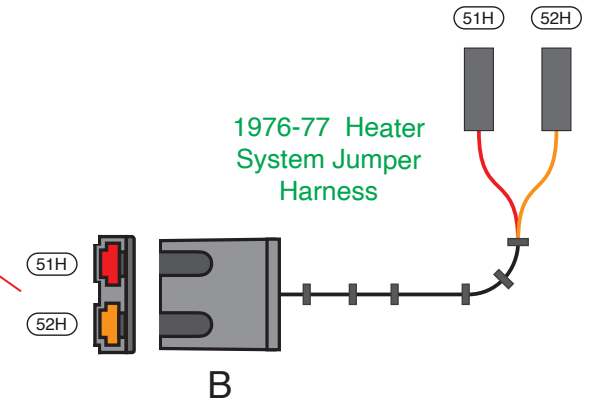
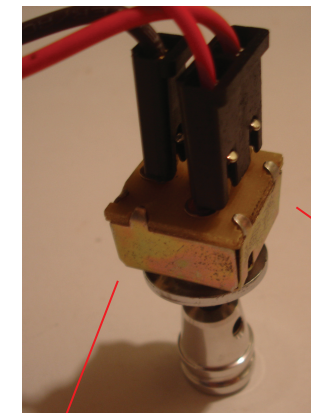
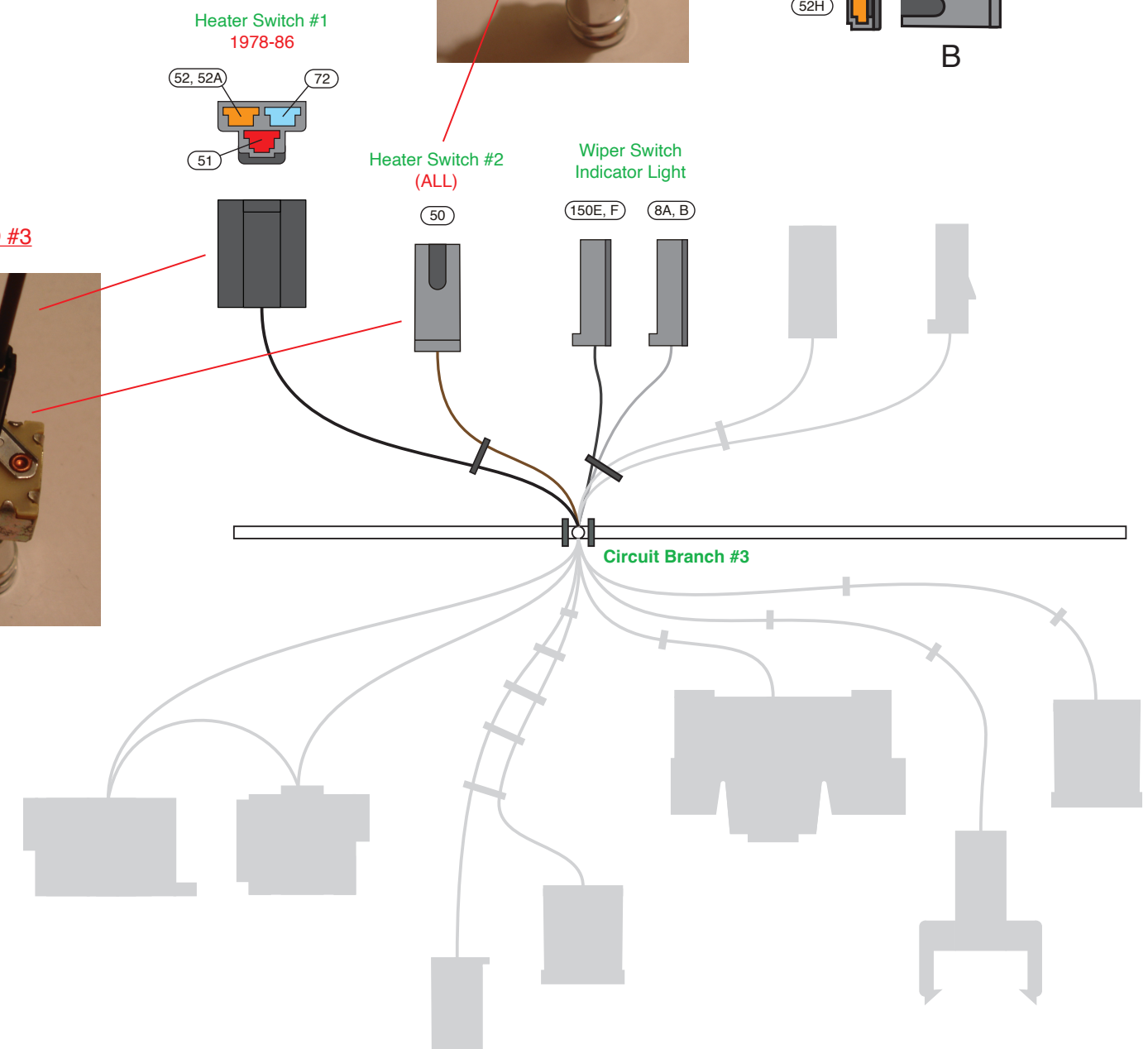
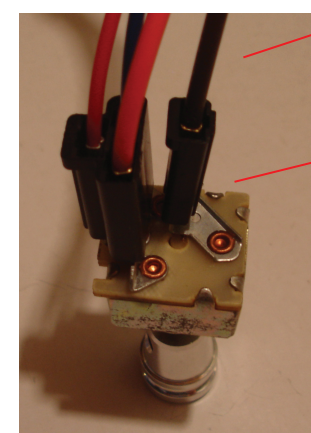

PHOTO #3



American Autowire

www.americanautowire.com 856-933-0801

PART # **510574**
 DESCRIPTION:
1976-86 Jeep CJ Classic Update Series Kit
 92970861 Rev 2.0 06/01/2023

Wiper System **Note: There are two different Wiper Systems available. Both systems are two speed systems. The Wiper Motor pigtail for the 1976-82 vehicles has three wires, and the Wiper Motor pigtail for the 1983-86 vehicles has four wires.**

For the **1976-82 vehicles**, there is a 3-wire Wiper Motor System. The Wiper Switch has five blade terminals and the Wiper Motor has a long pigtail with three wires and a 3-way connector.

Route the Wiper Motor pigtail to the Wiper Switch (**See photo #4**) and plug the 3-way connector onto the **Wiper Switch**. Obtain the **Wiper Switch #1 Connector** with the white wire (circuit 93), which is part of the Dash Harness, and attach it to the **Wiper Switch** where the blade terminal with the raised nib is located (**See photo #4**). This terminal can only connect one way. Obtain the **Wiper Switch #2 Connector** with the dark green wire (circuit 94), and attach it to the remaining blade terminal (**See photo #4**) on the Wiper Switch. This is the feed to the Windshield Washer Pump.

For the **1983-86 vehicles**, there is a 4-wire Wiper Motor System. The Wiper Switch has seven blade terminals and the Wiper Motor has a long pigtail with four wires and a 4-way connector. You will have to use the **1983-86 Wiper System Jumper Harness "C"** (see Page 3 – the Legend) for these vehicles.

Obtain the **1983-86 Wiper System Jumper Harness** and plug the 7 terminal connector onto the **Wiper Switch** (**See photo #5**). Obtain the pigtail from the Wiper Motor, and plug the 4-way connector into the 4-way connector of the **1983-86 Wiper System Jumper Harness**. Obtain **Wiper Switch Connectors #1 and #2** and plug those into the **1983-86 Wiper System Jumper Harness** (white wire to white wire and green wire to green wire).

1983-86 Wiper Switch Jumper Harness

Wire #	Wire Color	Printing	Description
91W	White	no printing	Wiper Low Speed.
92W	Dark Blue	no printing	Wiper High Speed.
93W	White	WIPER FEED	Fused feed to Wiper Switch Assembly.
93X	White	WIPER FEED	Fused feed to Wiper Switch for Washer Pump.
94W	Dark Green	no printing	Washer Pump feed.
95W	Black	no printing	Wiper Motor Park.
96W	Red	no printing	Wiper Motor Low Park.

Wiper Switch Connector #1

Wire #	Wire Color	Printing	Description
93	White	WIPER FEED	Fused feed to the Wiper Switch.

Wiper Switch Connector #2

Wire #	Wire Color	Printing	Description
94	Dark Green	no printing	Feed to the Washer Pump.

Ignition Switch #1 Connector This is the white connector with five wires. Plug this connector to the **Ignition Switch** first, before you plug the black **Ignition Switch Connector #2** to the **Ignition Switch**.

Wire #	Wire Color	Printing	Description
2B	Red	12V BATTERY	Battery feed from the Fuse Block.
2H	Red	12V BATTERY	Battery feed to the Ignition Switch #2 connector.
3A	Pink	IGNITION FEED	Ignition feed to the Fuse Block.
4A	Brown	IGNITION SW ACCY	Ignition Accessory feed to the Fuse Block.
5	Purple	NEUTRAL SAFETY SWITCH	Start feed to the Neutral Safety Switch.

1983-1986 Wiper Switch

PHOTO #5
1983-1986 Wiper Switch Connections

from Wiper Motor (not included with kit)

Wiper Switch #1 Wiper Switch #2

1983-86 Wiper System Jumper Harness

from Wiper Motor (not included with kit)

PHOTO #4
1976-1982 Wiper Switch Connections

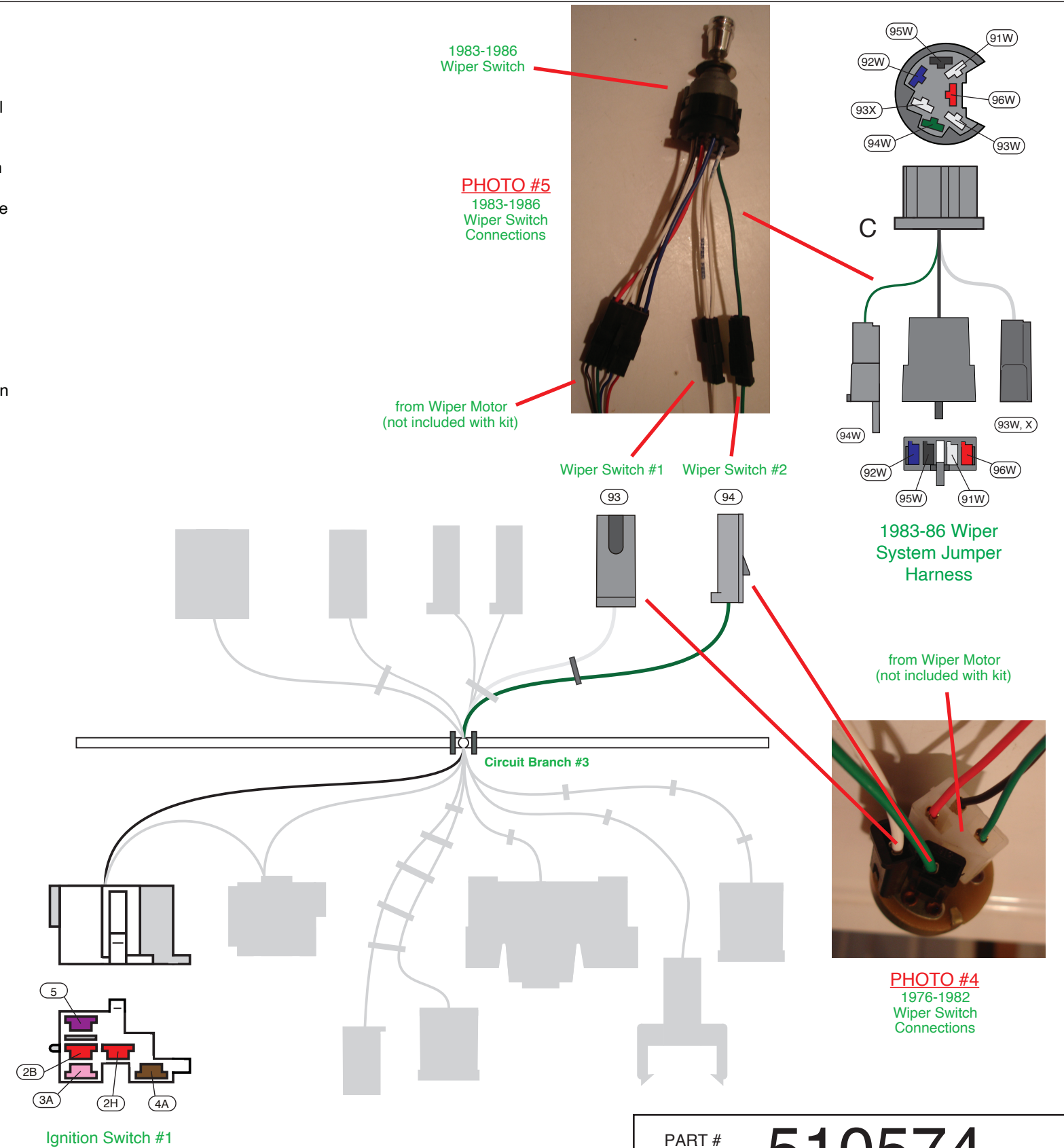

**American
Autowire**

www.americanautowire.com 856-933-0801

PART # **510574**

DESCRIPTION:
**1976-86 Jeep CJ
Classic Update Series Kit**

92970861 Rev 2.0 06/01/2023

Ignition Switch #2 Connector This is the black connector with three wires. Plug this connector to the Ignition Switch last, after you plug the white Ignition Switch Connector #1 to the Ignition Switch.

Wire #	Wire Color	Printing	Description
2H	Red	12V BATTERY	Battery feed from the Ignition Switch #1 connector.
33A, B	Tan	BRAKE LIGHT/SWITCH	Brake Warning Light prove-out.

Neutral Safety Switch/Start System **Note: There were two different factory Neutral Safety Switch/Start Systems available (see below).**

For 1976-79 Vehicles with an Automatic Transmission, the Neutral Safety Switch is located at the base of the Steering Column inside the vehicle. Plug the Neutral Safety Switch Connector, which is part of the Dash Harness, onto this Switch (**See photo #7**).

For 1980-86 Vehicles with an Automatic Transmission, the Neutral Safety Switch is located on the Transmission and the connection to the Transmission will be in the **Engine Kit 510575**. So you will have to obtain the **Neutral Safety Switch Jumper Harness "D"** (see Page 3 – the Legend) and plug it into the Neutral Safety Switch Connector (See photo #6). This will allow the Start circuit to continue to the Engine Kit.

For 1976-86 Vehicles with a Manual Transmission, there is no Neutral Safety Switch, so you will have to obtain the **Neutral Safety Switch Jumper Harness "D"** and plug it into the Neutral Safety Switch Connector (See photo #6). This will allow the Start circuit to continue to the Starter Solenoid.

Note: If you don't connect the Neutral Safety Switch Connector on the Dash Harness to either the 1976-79 Neutral Safety Switch, or to the Neutral Safety Switch Jumper Harness, your Starter Solenoid will not engage and your Engine will not crank.

Neutral Safety Switch Jumper Harness

Wire #	Wire Color	Printing	Description
5N	Purple	NEUTRAL SAFETY SWITCH	Jumper for the Neutral Safety Switch circuit.

Neutral Safety Switch Connector Note: If you have an Aftermarket Automatic Transmission Floor Shifter with a Neutral Safety Switch, extra length has been provided in this branch to reach the switch.

Wire #	Wire Color	Printing	Description
5	Purple	NEUTRAL SAFETY SWITCH	Start feed from the Ignition Switch to the Neutral Safety Switch.
6	Purple	STARTER SOLENOID-S	Start feed from the Neutral Safety Switch Connector to the Engine Compartment.

Back-up Switch System **Note: There are two different Back-up Switch/Systems available.**

For 1976-79 Vehicles with an Automatic Transmission, the Back-up Switch is located at the base of the Steering Column inside the vehicle. Plug the Back-up Switch Connector, which is part of the Dash Harness, onto this Switch (**See photo #7**).

For all other Vehicles the Back-up Switch in the Dash Harness will not be used and you can tape this back to the Main Trunk of the Dash Harness. For these vehicles, the Back-up Switch is located on the Transmission and the connection to the Transmission will be in the **Engine Kit 510575** (see the Engine Kit Assembly Instructions for the connection to the Back-up Switch).

Back-up Switch Connector **Note:** If you have an Aftermarket Automatic Transmission Floor Shifter with a Back-up Switch, extra length has been provided in this branch to reach the switch.

Wire #	Wire Color	Printing	Description
24A	Light Green	BACK UP LT SW	Feed to the Back-up Lights.
39B, C	Pink	12V IGNITION	Fused feed from the Fuse Block.

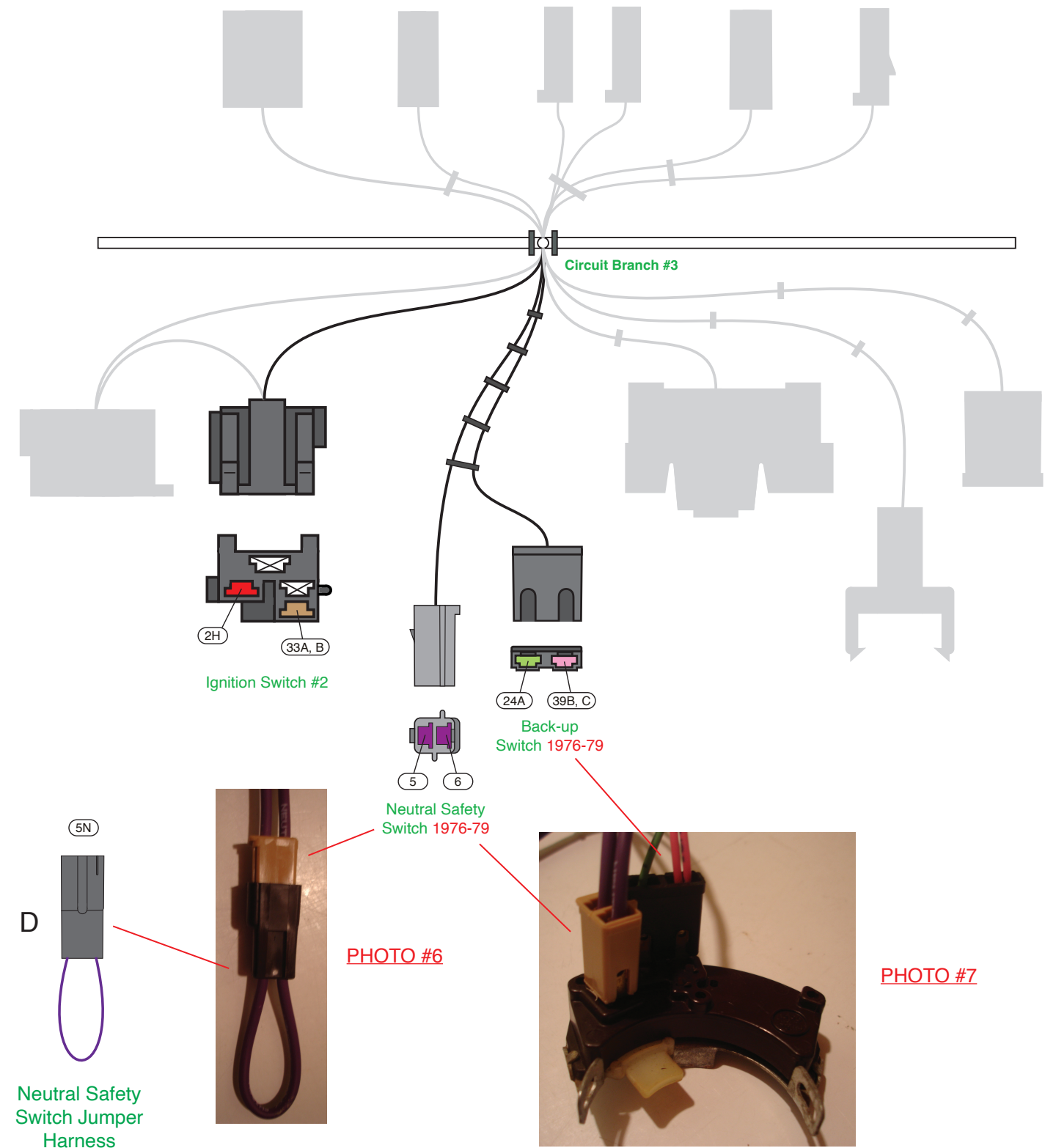

PART #	510574
DESCRIPTION:	1976-86 Jeep CJ Classic Update Series Kit
92970861	Rev 2.0 06/01/2023

Turn Signal Switch Connector If you are using the original factory Turn Signal Switch, plug the Turn Signal Switch Connector in the Dash Harness to the Turn Signal Switch. After the connectors are mated, you can attach the connectors to the original factory bracket that holds the connectors in place on the Steering Column.

American Autowire (AAW) Turn Signal Switch Wires to stock 1976-1986 Jeep CJ Turn Signal Switch.

AAW Wire#	AAW Wire Color	AAW Wire Printing	Connector Cavity	Jeep Wire Color
17B	White	Brake SW	P	White
19	Dark Green	Right Rear Turn	N	Dark Green
18	Yellow	Left Rear Turn	M	Yellow
16	Purple	Turn Switch Feed	L	Purple
27	Brown	Turn SW – Hazard	K	Brown
15A	Dark Blue	Right Front Turn	J	Dark Blue
14A	Light Blue	Left Front Turn	H	Light Blue
28	Black	Horn Relay Ground	G	Black
None	None	None	F *	Light Green
None	None	None	E *	Tan
8B	Gray	Dash Lights	D	Gray

NOTE: For the 1976-1986 vehicles, the Steering Column Horn Button switches ground for a Horn Relay, which then switches power to the Horns, similar to the AAW design.

* Cavities E and F, in the factory Jeep Turn Signal Switch, have wires for a Key-in-Ignition Switch Warning Buzzer, these wires are not included in the AAW Dash Harness.

For Aftermarket Steering Columns, connector “F” and terminals “G” have been provided (see Page 3 – the Legend). If the Turn Signal Switch on the Steering Column, doesn’t mate to the Turn Signal Switch connector on the Dash Harness, remove the connector on the Aftermarket Steering Column, crimp on terminals “G” and plug into connector “F” (see the list above for function and cavity identification).

Brake Switch Connector Connect to the **Brake Switch**. **Note:** If your original factory Brake Switch has a two wire pigtail, we have provided the mating connector and terminals. Route your Dash Harness Brake Switch branch to the pigtail, cut wires 17A, 17B, and 40D to length, crimp on terminal “J” (see Page 3 - the Legend) to the orange wire (40D) and crimp on terminal “H” to the combination of the light blue wire (17A) and the white wire (17B), plug these wires into connector “Q” (polarity doesn’t matter). Now connect to the Brake Switch pigtail.

Wire #	Wire Color	Printing	Description
17A	Light Blue	THIRD BRAKE LIGHT	Feed to the Third Brake Light.
17B	White	BRAKE SW	Brake Switch feed to the Turn Signal Switch.
40D	Orange	BRAKE SWITCH	Fused feed from Fuse Block.

Automatic Transmission Kick-Down Switch Connector (1976-79 vehicles only) this switch allows down shifts of your Automatic Transmission under certain conditions.

For 1976-79 Vehicles with an Automatic Transmission, plug this connector onto the **Auto Trans Kick-Down Switch** which is located on the Accelerator Pedal.

Wire #	Wire Color	Printing	Description
39F, G	Pink	12V IGNITION	Fused feed from the Fuse Block.
55	Orange/Black	no printing	Feed to the Kick-Down Solenoid on the Automatic Transmission.

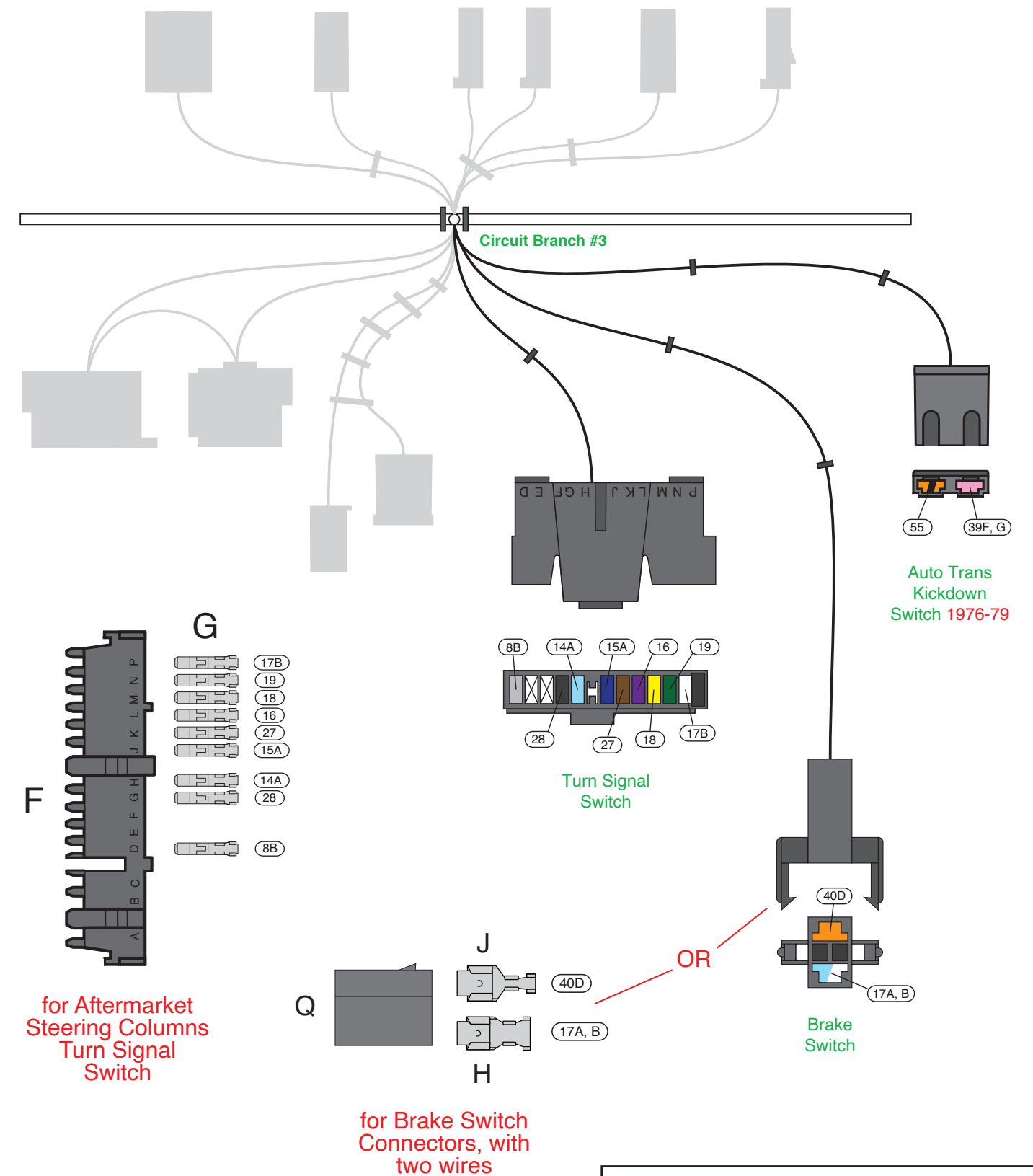

**American
Autowire**

www.americanautowire.com 856-933-0801

PART # **510574**

DESCRIPTION:

**1976-86 Jeep CJ
Classic Update Series Kit**

92970861 Rev 2.0 06/01/2023

Circuit Branch #4

Ground #2 **Note: Be sure to attach this ground ring terminal to a good vehicle ground. If not attached, the Cigar Lighter, and the following Indicator Lights will not function: Headlight Switch, Wiper Switch, Defroster, Temperature, Heat/Vent, and Heater Fan.**

Wire #	Wire Color	Printing	Description
150F, G	Black	GROUND	Ground for the Indicator Lights and the Cigar Lighter.

Cigar Lighter Ground Connector Connect to the **Cigar Lighter Ground**.

Wire #	Wire Color	Printing	Description
150G, H	Black	GROUND	Ground for the Cigar Lighter.

Cigar Lighter Feed Connector Connect to the **Cigar Lighter feed terminal**.

Wire #	Wire Color	Printing	Description
40B	Orange	12V BATTERY-FUSED	Fused Battery feed to the Cigar Lighter.

Instrument Cluster Connections These connections will plug into the **Cluster Connector Kit 510578**. Instructions are included in that kit.

Cluster Connector "A"

Wire #	Wire Color	Printing	Description
4E	Brown	no printing	Cluster 12V Ignition Accessory feed.
8C, D	Gray	DASH LIGHTS	Fused 12V from the Fuse Block for the Cluster Illumination Lights.
39C, D	Pink	12V IGNITION	Fused 12V Ignition feed.
150Q	Black	GROUND	Cluster Ground

Cluster Connector "B"

Wire #	Wire Color	Printing	Description
11B	Light Green	HI BEAM INDICATOR LIGHT	Feed to the High Beam Indicator Light.
14B	Light Blue	LEFT DASH IND	Feed for the Left Turn Signal Indicator Light.
15B	Dark Blue	RIGHT DASH IND	Feed for the Right Turn Signal Indicator Light.
30	Tan	GAS GAUGE	Fuel Gauge Signal from the Fuel Tank Sending Unit.
33B	Tan	BRAKE LIGHT/SWITCH	Brake Warning Light Signal to ground.
35	Dark Green	WATER TEMP SENDER	Water Temperature Sender Signal from the Engine.
121	White	COIL-->TACH	Feed for an Aftermarket Tachometer (see the Warning Sheet) .
131	Dark Blue	no printing	4WD Light Signal to ground.

Cluster Connector "C" This connector contains the wires for an Aftermarket Electric Speedometer. **Wires "400" and "401" must remain twisted together.**

Wire #	Wire Color	Printing	Description
139	Pink/White	SPEEDO POWER	Fused 12V feed for the Electric Speedometer.
151	Black/White	SPEEDO GROUND	Electric Speedometer Ground.
400	Yellow	VSS GROUND	Vehicle Speed Sensor Ground.
401	Purple	VSS SIGNAL	Vehicle Speed Sensor Signal
402	Purple/White	VSS POWER	Vehicle Speed Sensor Power.

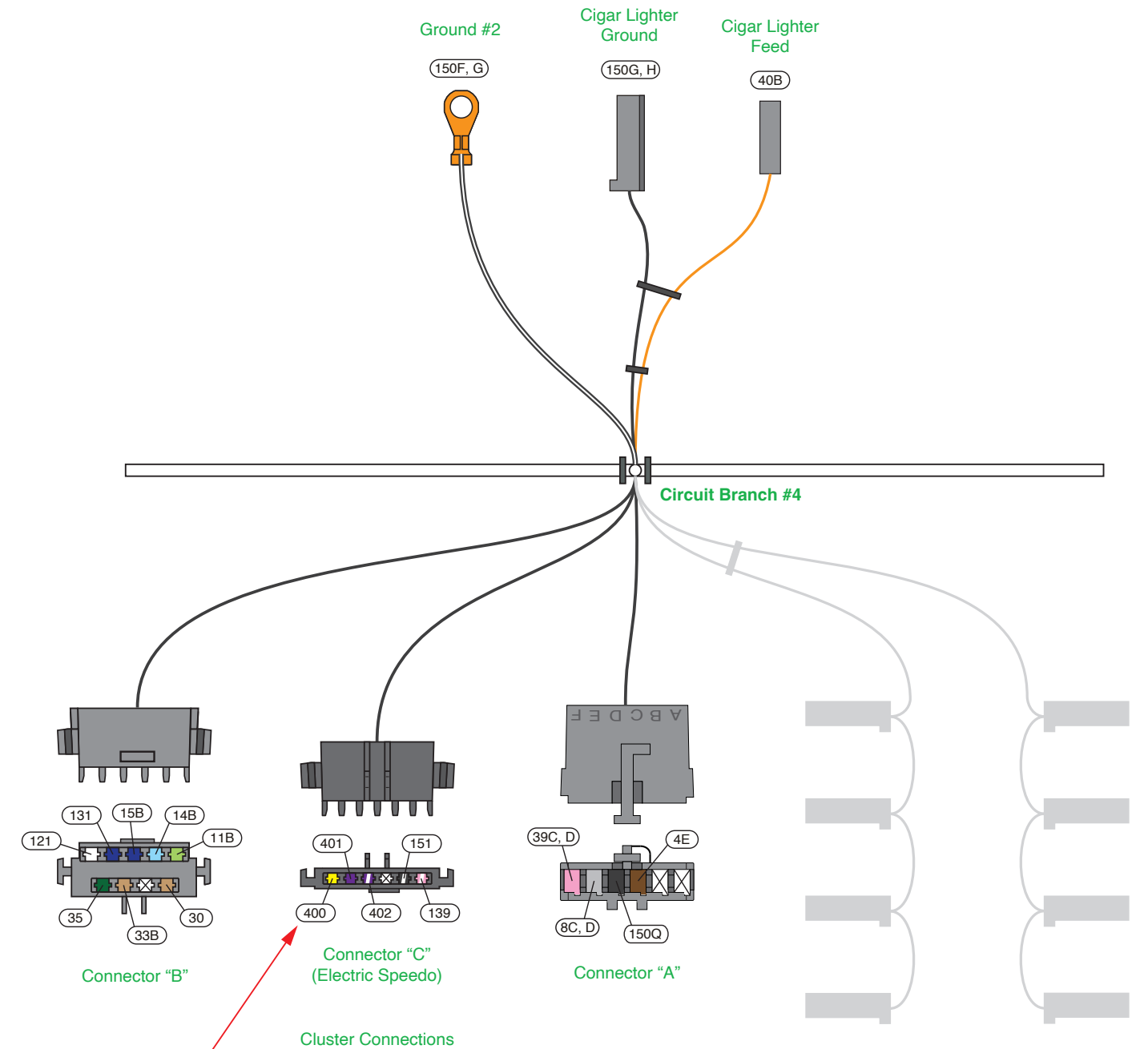

NOTE: Wires 400 and 401, must be twisted together, their entire length.



**American
Autowire**

www.americanautowire.com 856-933-0801

PART # **510574**

DESCRIPTION:

**1976-86 Jeep CJ
Classic Update Series Kit**

92970861 Rev 2.0 06/01/2023

Defroster Indicator Light Connectors

Wire #	Wire Color	Printing	Description
8E, F, G	Gray	DASH LIGHTS	Defroster Indicator Light feed.
150H, J	Black	GROUND	Defroster Indicator Light ground.

Temperature Indicator Light Connectors

Wire #	Wire Color	Printing	Description
8G, H, J	Gray	DASH LIGHTS	Temperature Indicator Light feed.
150J, K	Black	GROUND	Temperature Indicator Light ground.

Heat/Vent Indicator Light Connectors

Wire #	Wire Color	Printing	Description
8J, K	Gray	DASH LIGHTS	Heat/Vent Indicator Light feed.
150K, L	Black	GROUND	Heat/Vent Indicator Light ground.

Heater Fan Switch Indicator Light Connectors

Wire #	Wire Color	Printing	Description
8K	Gray	DASH LIGHTS	Heater Fan Switch Indicator Light feed.
150L	Black	GROUND	Heater Fan Switch Indicator Light ground.

Circuit Branch #5

Dash Light Candelabra Connector This connector is provided if you need a Dash Light feed for an optional component. Attach the **Radio Illumination Light**, the **Clock Light Jumper Harness**, the **Tachometer Light**, or any other option to this Candelabra Connector. **Note:** If needed, large male bullet terminals "N" and large sleeves "P" are provided in this kit, which will plug into the Candelabra. Extra Light Sockets and terminals are available in the **Cluster Kit 510578**, for connection to the components.

Wire #	Wire Color	Printing	Description
8D	Gray	DASH LIGHTS	Various Dash Light feeds.

Radio These circuits are provided for your Radio.

Wire #	Wire Color	Printing	Description
43	Tan	RADIO	12V Fused Accessory Feed for the Radio. "On/Off" power.
99A	Yellow	RADIO BAT	12V Fused Battery Feed for the Radio Memory.
150M	Black	GROUND	Radio Ground.

Aftermarket Electric Speedometer Ground Attach this wire to a good vehicle ground.

Note: Do not attach this ring terminal with any other ground ring terminal; it must be grounded all by itself to a good vehicle ground.

Wire #	Wire Color	Printing	Description
151	Black/White	SPEEDO GROUND	Ground for an Aftermarket Electric Speedometer.

Oil Pressure Gauge Connectors Attach the Dark Blue (circuit 31) and the Pink (circuit 39D) wires to the **Oil Pressure Gauge** first (see **Figure B**). Next install a light bulb #1895 or equivalent (not included in the kit), into the light socket (circuit 8H), and seat the light socket in the Oil Pressure Gauge. Finally, attach the ground ring terminal (circuits 150P, Q) to the **Oil Pressure Gauge Mounting Bracket** using a **10-32 Lock Nut** which is included in the Dash Harness Kit.

Wire #	Wire Color	Printing	Description
8H	Gray	DASH LIGHTS	Oil Pressure Gauge Illumination Light.
31	Dark Blue	OIL PRESSURE SENDER	Oil Pressure Sender Signal from the Engine.
39D	Pink	12V IGNITION	Fused 12V Ignition feed to the Oil Pressure Gauge.
150P, Q	Black	GROUND	Ground for the Oil Pressure Gauge.

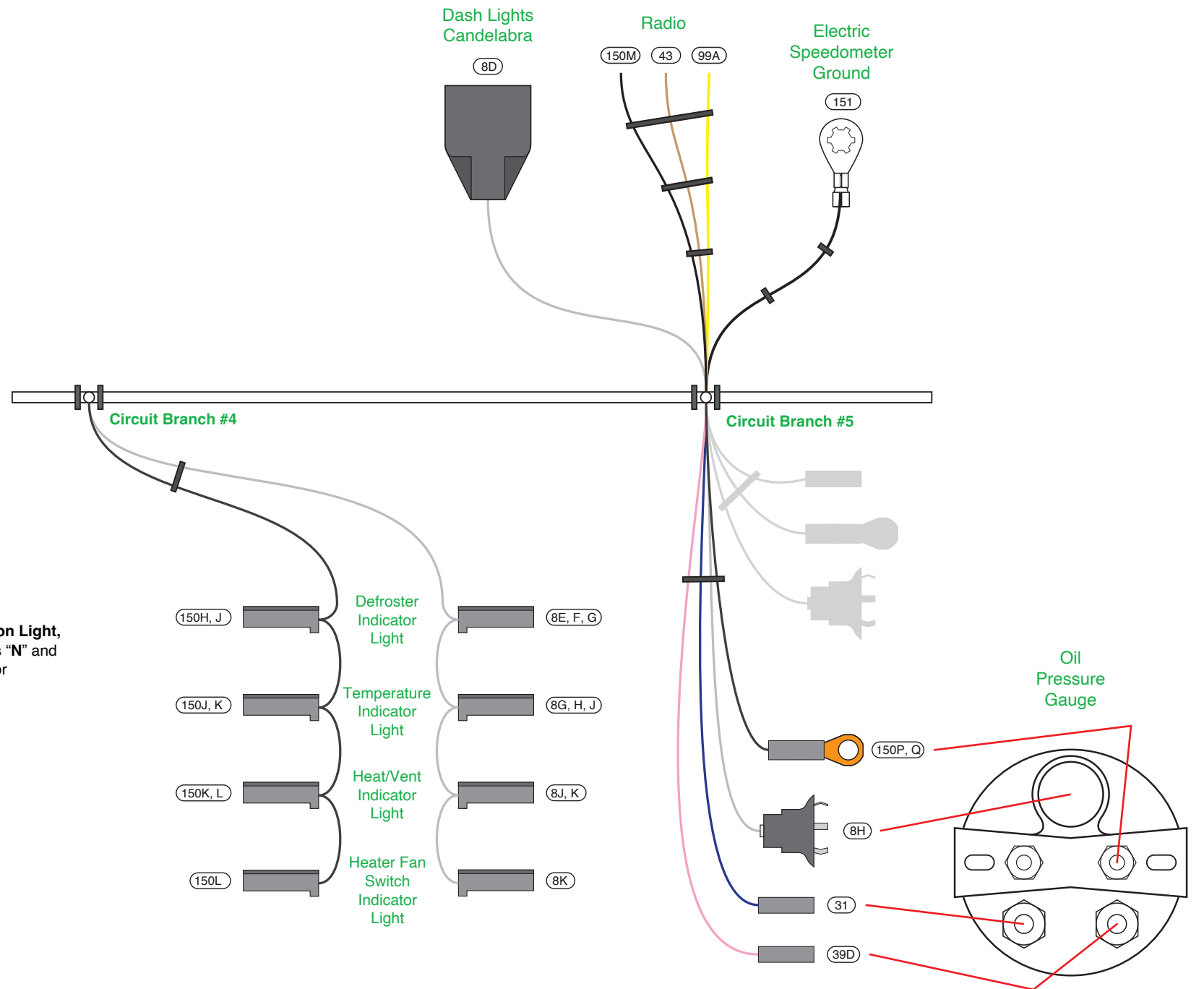

FIGURE "B"

American Autowire
www.americanautowire.com 856-933-0801

PART # **510574**
DESCRIPTION:
1976-86 Jeep CJ Classic Update Series Kit
92970861 Rev 2.0 06/01/2023

Voltmeter Connectors Attach the Pink (circuit 39G) wire to the **Voltmeter** first (see **Figure C**). Next install a light bulb #1895 or equivalent (not included in the kit), into the light socket (circuit 8F), and seat the light socket in the Voltmeter. Finally, attach the ground ring terminal (circuits 150N, P) to the **Voltmeter Mounting Bracket** using a **10-32 Lock Nut** which is included in the Dash Harness Kit.

Wire #	Wire Color	Printing	Description
8F	Gray	DASH LIGHTS	Voltmeter Illumination Light.
39G	Pink	12V IGNITION	Fused feed from the Fuse Block.
150N, P	Black	GROUND	Voltmeter Ground.

Circuit Branch #6

Right Hand Courtesy Lamp Connector Plug into one of the **Courtesy Light Jumper Harnesses "E"** (see **Page 3 – the Legend**), and attach to the Lower Instrument Panel. **Note:** The Light Socket of the **Courtesy Light Jumper Harness** requires a #631 light bulb (not included with this kit).

Wire #	Wire Color	Printing	Description
40H	Orange	12V BATTERY-FUSED	Fused Battery feed for the Courtesy Lights.
156B	White	CTSY GROUND	Courtesy Light ground through the Headlight Switch.

Ground #3 **Note:** Be sure to attach this ground ring terminal to a good vehicle ground. If not attached your Radio, Voltmeter, Oil Pressure Gauge, and Cluster will not be functional.

Wire #	Wire Color	Printing	Description
150M	Black	GROUND	Radio Ground.
150N	Black	GROUND	Voltmeter Ground.

Blower Motor Resistor Connector Note: This connector is only required for **1978-86 Vehicles**. Plug this connector onto the Blower Motor Resistor.

51	Red	no printing	Blower Motor Low Speed.
52A	Orange	HEAT/AIR	Blower Motor High Speed.
72	Light Blue	no printing	Blower Motor Medium Speed.

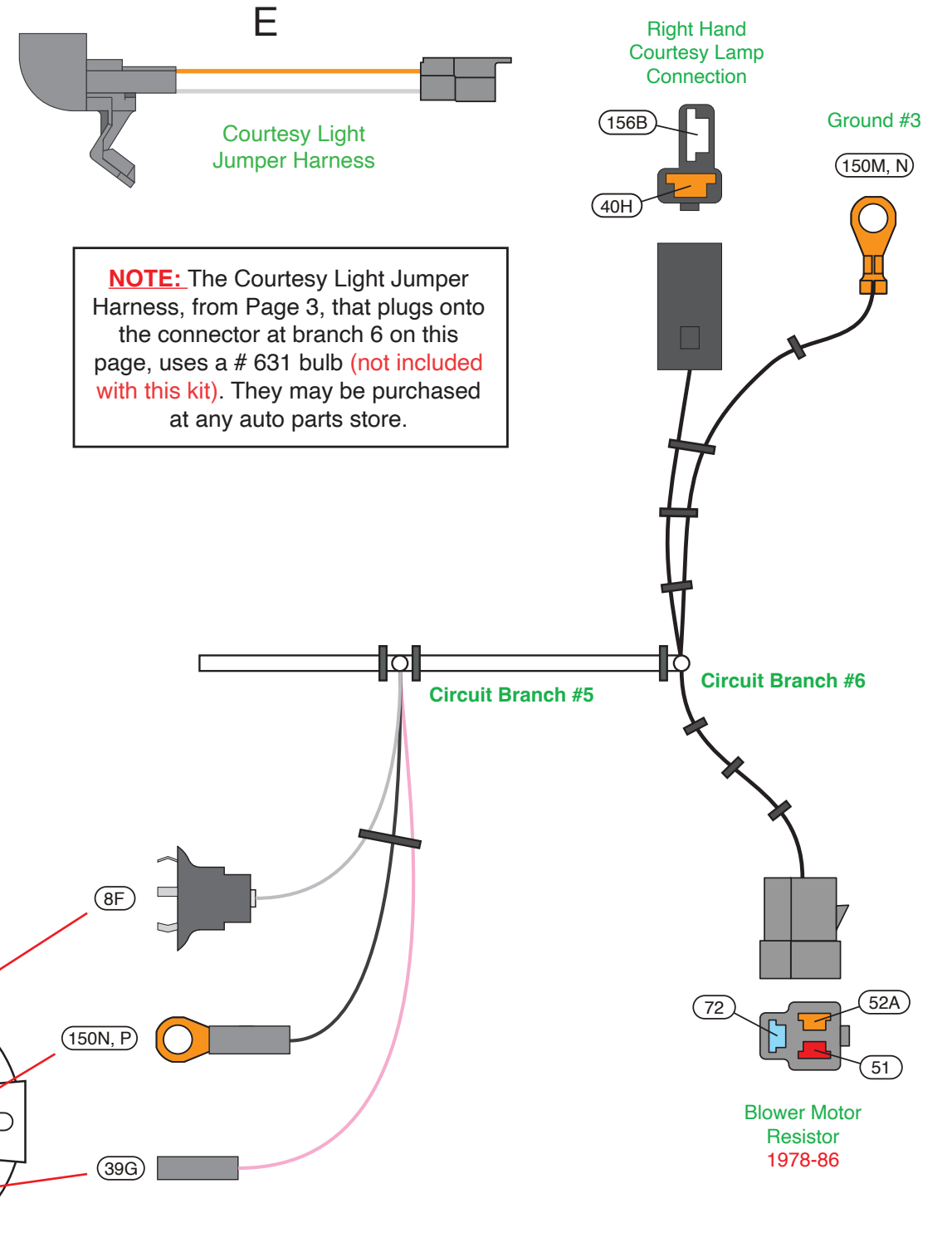

FIGURE "C"



PART # **510574**
 DESCRIPTION:
1976-86 Jeep CJ
Classic Update Series Kit
 92970861 Rev 2.0 06/01/2023

THIS PAGE HAS BEEN
INTENTIONALLY LEFT BLANK



**American
Autowire**

www.americanautowire.com 856-933-0801

PART # **510574**

DESCRIPTION:

1976-86 Jeep CJ
Classic Update Series Kit

92970861 Rev 2.0 06/01/2023